

INSTRUCTIONS FOR USE:

- The customer is responsible for static calculation, formwork plans, documenting, safely formwork assembly & disassembly (in accordance with the applicable laws, standards and rules), implementing and continually updating a hazard assessment at every job-site.
- All instructions regarding technical operation and function have to be observed carefully. Exceptional use requires a separate design calculation.
- Generally, only flawless material must be used. Damaged components have to be sorted out. In case of usage of damaged material, nothing here is applicable and you are using it at your own risk.
- **Note:** Always put load (q) on H20 beams perpendicularly to strong axis (x) of beam (see picture). Only in this case you can calculate with moment of inertia $I_x = 4.613 \text{ cm}^4$ and only in this case you can use Chart of Charge values.

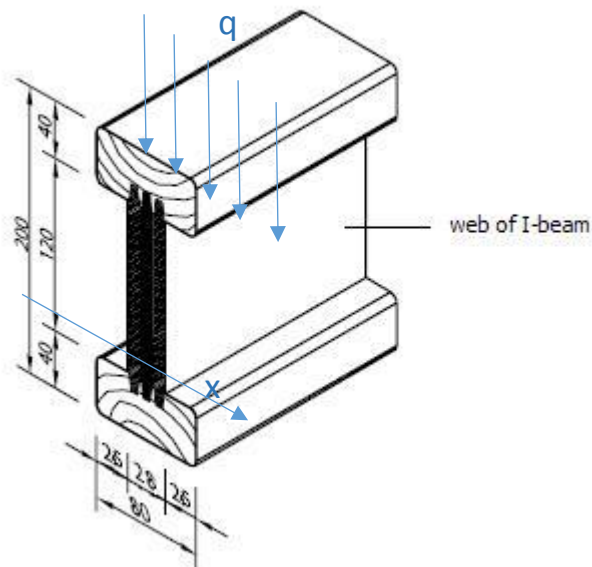

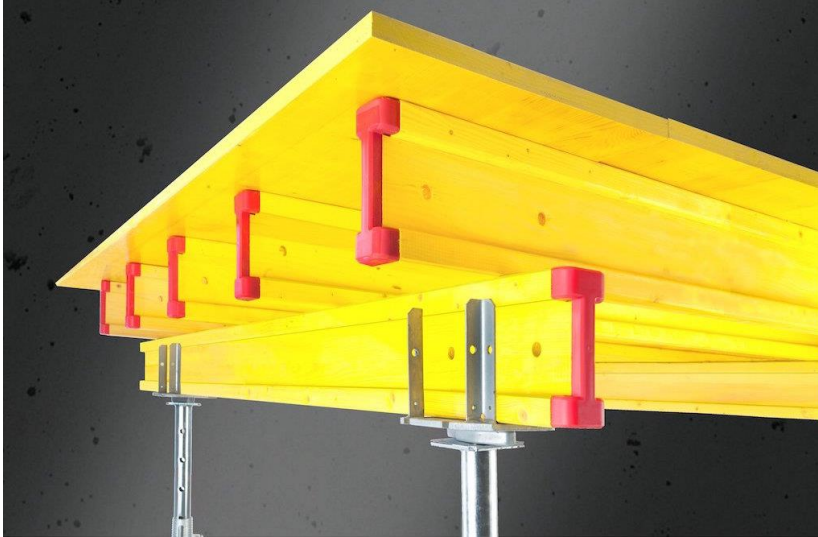

- A beam must be placed under each shuttering panel joint. The shuttering panels are placed on top of the secondary beams and tacked in place. The rigid shuttering structure must be braced against the building.
- Safety rails must be erected on the edges of the structure, in line with the your country's regulations for safety and health protection in shuttering and scaffolding.
- The existing slab thickness and the selected secondary beam spacing, which depends upon the type and size of the selected shuttering panel, determine the maximum permitted distance between primary beams.
- Using the selected primary beam spacing and slab thickness, the maximum permitted distance between props (permissible load capacity of props min 20 kN) for the primary beam axes can then be determined.
- All the figures necessary for the efficient use of slab formwork can be quickly and precisely determined with the help of the following table.

Chart of charge values

Floor thickness (cm)	Total load (kN/m ²)	Max. permissible support width of the crossbeam (m) = distance between main beams (m)				Max. permissible support width = distance between supports (m)								
		Distance between crossbeams (m)				Selected distance between the main beams (m)								
		0.50	0.625	0.667	0.75	1.00	1.25	1.50	1.75	2.00	2.25	2.50	3.00	3.50
10	4.38	3.70	3.43	3.35	3.22	2.93	2.72	2.50	2.31	2.16	2.04	1.93	1.70	1.45
12	4.91	3.50	3.24	3.17	3.05	2.77	2.57	2.36	2.19	2.05	1.92	1.82	1.52	1.30
14	5.43	3.32	3.09	3.02	2.91	2.64	2.45	2.24	2.08	1.94	1.82	1.64	1.37	1.18
16	5.95	3.19	2.96	2.90	2.79	2.54	2.35	2.14	1.98	1.85	1.66	1.50	1.25	1.07
18	6.48	3.07	2.85	2.79	2.69	2.44	2.25	2.06	1.90	1.72	1.53	1.38	1.15	0.99
20	7.00	2.97	2.76	2.70	2.60	2.36	2.17	1.97	1.82	1.59	1.42	1.28	1.07	0.91
22	7.53	2.88	2.68	2.62	2.52	2.29	2.09	1.90	1.69	1.48	1.32	1.19	0.99	0.85
24	8.05	2.81	2.61	2.55	2.45	2.23	2.02	1.84	1.58	1.39	1.23	1.11	0.93	0.80
26	8.57	2.74	2.54	2.49	2.39	2.18	1.95	1.73	1.49	1.30	1.16	1.04	0.87	0.75
28	9.10	2.67	2.48	2.43	2.34	2.12	1.89	1.63	1.40	1.23	1.09	0.98	0.82	0.71
30	9.68	2.61	2.43	2.38	2.29	2.06	1.83	1.54	1.32	1.15	1.03	0.93	0.77	0.65
35	11.25	2.49	2.31	2.26	2.18	1.90	1.59	1.32	1.14	0.99	0.89	0.80	0.66	0.56
40	12.83	2.38	2.21	2.17	2.07	1.74	1.39	1.16	1.00	0.87	0.78	0.70	0.58	0.49
45	14.40	2.29	2.13	2.07	1.94	1.55	1.24	1.04	0.89	0.78	0.69	0.62	0.51	0.44
50	15.97	2.22	2.03	1.96	1.84	1.40	1.12	0.94	0.80	0.70	0.62	0.56	0.46	0.40
55	17.54	2.15	1.93	1.87	1.69	1.27	1.02	0.85	0.73	0.63	0.56	0.51	0.42	0.36
60	19.11	2.07	1.85	1.75	1.56	1.17	0.94	0.78	0.66	0.58	0.52	0.46	0.39	0.33
65	20.68	1.98	1.72	1.62	1.44	1.08	0.87	0.72	0.61	0.54	0.48	0.43	0.36	0.31
70	22.26	1.91	1.60	1.50	1.34	1.01	0.81	0.66	0.57	0.50	0.44	0.40	0.33	0.28
75	23.83	1.85	1.50	1.41	1.25	0.94	0.75	0.62	0.53	0.47	0.41	0.37	0.31	0.27
80	25.40	1.76	1.41	1.32	1.17	0.88	0.71	0.58	0.50	0.44	0.39	0.35	0.29	0.25
85	26.97	1.65	1.32	1.24	1.11	0.83	0.66	0.55	0.47	0.41	0.37	0.33	0.27	0.23
90	28.54	1.56	1.25	1.17	1.05	0.79	0.62	0.52	0.44	0.39	0.35	0.31	0.26	0.22
95	30.11	1.48	1.19	1.11	1.00	0.99	0.75	0.59	0.49	0.42	0.37	0.33	0.29	0.25
100	31.69	1.41	1.13	1.06	0.94	0.71	0.56	0.47	0.40	0.35	0.31	0.28	0.23	0.20

An example of calculation: Floor thickness: 20 cm, distance between crossbeams: 0.75 m; we are looking for the distance between the main beams and the supports. The permissible distance between the main beams according to the **table 1 = 2.60 m**. The identical or the closest distance between the main beams in the **table 2 = 2.5 m**. Look for the permissible distance between supports in the **table 2**, read vertically down the column "2.50 m" and horizontally in the row "20 cm" of the column "floor thickness", the result is **1.28 m**. Caution: Examine the supports to ensure the corresponding carrying force.

Bending which occurs in formwork beams that are loaded by a particular force at different space intervals of support.

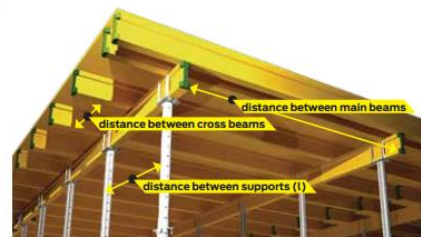
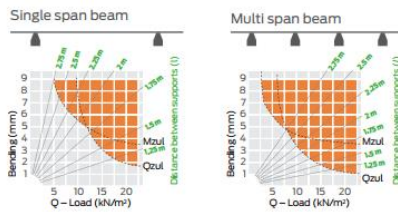

These tables do not render stability verification unnecessary!

- Do not exceed the permitted fresh-concrete pressures. Over-high pouring rates overload the formwork, cause greater deflection and risk breakage.

With regard to safe and technically correct use of our products - all relevant local safety rules, laws, regulations and safety instructions of national institutes and/or local authorities have to be followed.